

FILTER SOLUTIONS

Carbon Steel & Stainless Steel Simplex Inline Fabricated Strainers Dimensional Data for 150# Flanged Strainers

Inlet/Outlet Size	2 "	2.5 "	3 "	4 "	6 "	8 "
Housing Dia. in Pipe Size	4 "	4 "	6 "	6 "	8 "	10 "
A	12 "	12 "	14 "	14 "	18 "	22 "
B	4 "	4 "	5.5 "	5.5 "	7.5 "	9.5 "
C	16 "	16 "	21.25 "	21.25 "	27.25 "	34.625 "
D	8.5 "	12 "	11.75 "	16 "	15.75 "	21.125 "
E	11 "	14 "	15 "	18 "	21 "	28 "
Basket Dia.	2 "	2 "	3.75 "	3.75 "	5.75 "	7.75 "
Basket Length	6 "	9 "	8 "	12 "	12 "	16 "
Ship'ng. Wt (Lbs)	55	65	102	112	190	320
Min. Perf. Size	1/32 "	1/32 "	1/32 "	1/32 "	1/16 "	1/16 "
Min. Basket Open Area Sq. Inches	10	15	22	38	85	151

Standard Perforation Diameter 1/8"

CSA B51 Certified with Canadian Registration Number (CRN)

Standard Design Pressure & Temperature 285 PSIG @ 100 Deg. F. or 215 PSIG @ 350 Deg. F.

Special Design Pressures & Temperatures available upon request

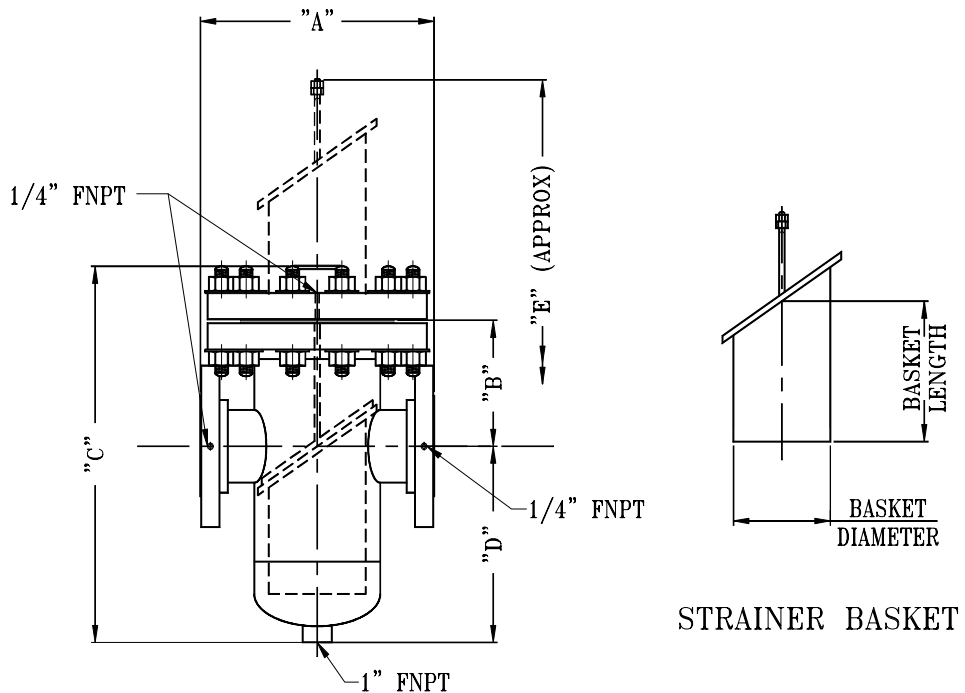

STRAINER HOUSING